

CLARK®

air



1/4" AIR DIE GRINDER (C/W 5" EXTN)

MODEL NO: CAT130

PART NO: 3120144

OPERATING & MAINTENANCE INSTRUCTIONS

UK
CA | CE

ORIGINAL INSTRUCTIONS

GC0522 - Rev3

INTRODUCTION





Thank you for purchasing this CLARKE Die Grinder which is ideal for light tasks such as automotive porting & polishing applications.

Before attempting to use this product, please read this manual thoroughly and follow the instructions carefully. In doing so you will ensure the safety of yourself and that of others around you, and you can look forward to your purchase giving you long and satisfactory service.

Your Die Grinder has been designed to give long and trouble free service. If, however, having followed the instructions in this booklet carefully, you encounter problems, take the unit to your local CLARKE dealer.

IMPORTANT

Please read all of the safety and operating instructions carefully before using this product. The following safety symbols are to be found on the machine.

	Read this instruction booklet carefully before use.		Wear ear protection.
	Wear eye protection.		Wear dust mask.

GUARANTEE

This product is guaranteed against faulty manufacture for a period of 12 months from the date of purchase. Please keep your receipt which will be required as proof of purchase.

This guarantee is invalid if the product is found to have been abused or tampered with in any way, or not used for the purpose for which it was intended.

Faulty goods should be returned to their place of purchase, no product can be returned to us without prior permission.

This guarantee does not effect your statutory rights.

GENERAL SAFETY RULES



CAUTION: FAILURE TO FOLLOW THESE PRECAUTIONS COULD RESULT IN PERSONAL INJURY, AND/OR DAMAGE TO PROPERTY.

WORK ENVIRONMENT

1. Keep the work area clean and tidy.
2. Dress appropriately - Do not wear loose clothing or jewellery. Tie long hair out of the way.
3. Keep children and visitors away - Do not let children handle the tool.
4. Do not operate the tool where there are flammable liquids or gases.

USE OF POWER TOOLS

1. Stay alert and use common sense - do not operate the air tool when you are tired or under the influence of alcohol, drugs or medication.
2. Always wear eye protectors when using the tool - Eye protectors must provide protection from flying particles from the front and the side.
3. Always wear ear protectors when using the air tool.
4. Do not overreach - Keep proper footing and balance at all times.
5. Never use oxygen, CO², combustible gases or any type of bottled gas as a source of power for the tool.
6. Do not connect the air supply hose with your finger on the trigger.
7. Do not exceed the maximum pressure for the tool of 90 psi / 6.2 bar.
8. Check hoses for leaks or worn condition before use, and ensure that all connections are secure.
9. Do not use the tool for any other purpose than that described in this manual.
10. Keep the air supply hose away from heat, oil and sharp edges.
11. Do not fit the tool to any stand or clamping device that may damage it.
12. Do not carry out any alterations or modifications to the tool.
13. Always disconnect from the air supply when:
 - Performing any maintenance.
 - The tool is not in use.

- The tool will be left unattended.
 - Moving to another work area.
 - Passing the tool to another person.
14. Never use the tool if it is defective or operating abnormally.
 15. The tool should be serviced at regular intervals by qualified service personnel.
 16. Avoid damaging the tool for example by applying excessive force of any kind.
 17. Always maintain the tool with care. Keep it clean for the best and safest performance.
 18. Quick change couplings should not be located at the tool. They add weight and could fail due to vibration.
 19. Do not force or misuse the tool. It will do a better and safer job at the rate for which it was designed.
 20. Do not remove any labels. Damaged labels should be replaced.
 21. This tool vibrates with use. Vibration may be harmful to your hands or arms. Stop using the tool if discomfort, a tingling feeling or pain occurs. Seek medical advice before resuming use.

TRANSPORTATION AND STORAGE

1. Never carry the tool by the air supply hose.
2. Never carry the tool with your finger on the trigger.
3. When not in use the tool must be disconnected from the air supply and stored in a dry place out of the reach of children (preferably in a locked cabinet).
4. Avoid storing the tool in environments where the temperature is below 0°C.

OVERVIEW

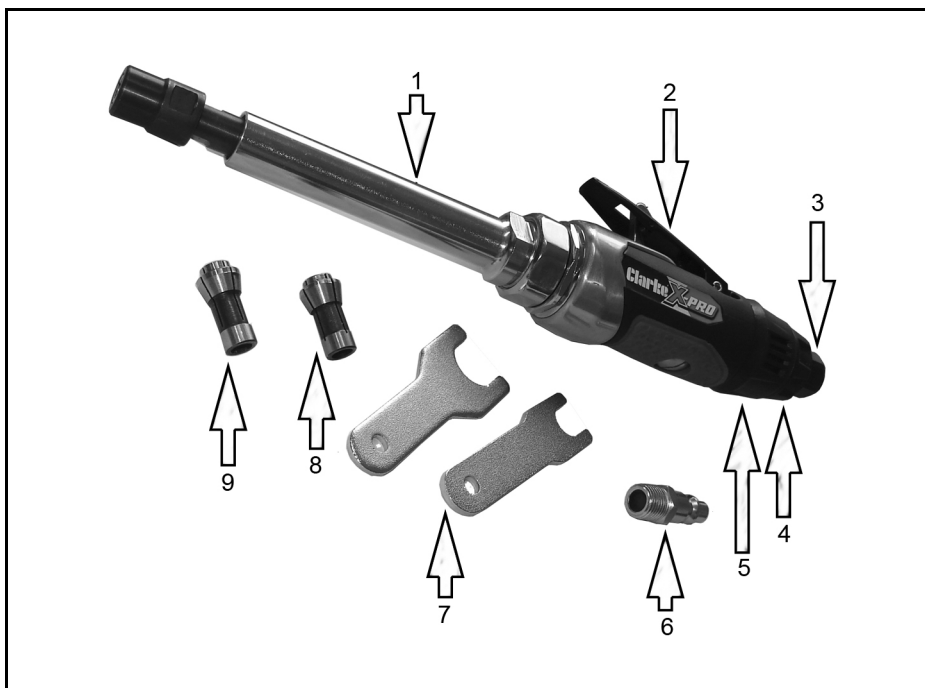

When opening the carton for the first time, check against the following list that all the items are present. Any damage or deficiency should be reported to your CLARKE dealer immediately.

NO	DESCRIPTION	NO	DESCRIPTION
1	5" Die Grinder (with 1/4" Collet)	6	Male Snap Connector
2	Trigger	7	2 x Collet Wrenches
3	Air Inlet	8	6 mm Collet
4	Speed Control	9	1/8" Collet
5	Air Exhaust Deflector		

COMPRESSED AIR REQUIREMENTS



WARNING: COMPRESSED AIR CAN BE DANGEROUS. ENSURE THAT YOU ARE FAMILIAR WITH ALL PRECAUTIONS RELATING TO THE USE OF COMPRESSORS AND COMPRESSED AIR SUPPLY.

- Use only clean, dry, regulated compressed air as a power source.
- Air compressors used with the tool must comply with the appropriate European Community Safety Directives.
- A build-up of moisture or oil in the air compressor will accelerate wear and corrosion in the tool. ensure any moisture is drained from the compressor daily and the inlet filter is kept clean.
- If an unusually long air hose is required, (over 8 metres), the line pressure or the hose inside diameter may need to be increased.
- The air hose must be rated at least 150% of the maximum operating pressure of the tool.

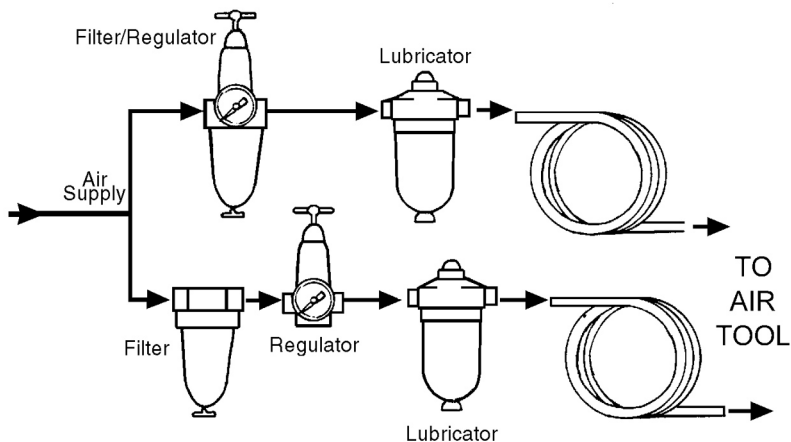

- A typical air line layout is shown above. If an automatic in-line filter/regulator is used, it will keep the tool in good condition, but should be regularly checked and topped up with oil. SAE 10 oil should be used, and the lubricator adjusted to approx 2 drops per minute.
- Never exceed the maximum operating pressure for the tool. It is recommended that air pressure to this tool does not exceed 90 psi at the tool when running. Higher pressures and unclean air will shorten the life of the tool due to faster wear and is a possible safety hazard.

BEFORE USE



WARNING: COMPRESSED AIR CAN BE DANGEROUS. ENSURE THAT YOU ARE FAMILIAR WITH ALL PRECAUTIONS RELATING TO THE USE OF AIR COMPRESSORS AND COMPRESSED AIR SUPPLIES.

NOTE: Ensure the compressor is turned off.

1. Remove the blanking plug from the inlet of the tool.
2. If required, connect an in-line mini oiler to the tool.
 - A mini oiler helps to prolong the life of the air tool.
3. If a mini-oiler is not being used, run a few drops of oil through the tool before use. It can be entered through the inlet strainer or via the hose at the nearest connection to the air supply.
4. Connect a suitable hose to the air inlet as shown.
5. Connect the other end of the hose to the compressor.

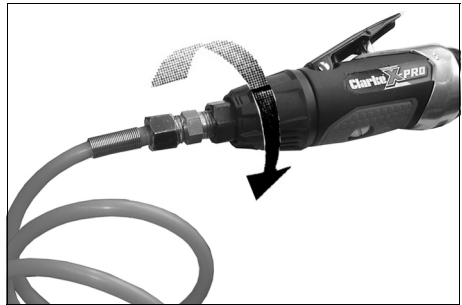

Your air tool is now ready for use.

You can fit a whip hose with a quick fit coupling if required (available from your Clarke dealer).

INSTALLING THE COLLET

1. Select the grinding stone you require.
2. Three collets of different sizes are provided. Select whichever fits the shank of the stone you have chosen.
 - The larger collet is probably already installed in the grinder.
3. If another collet is to be used, undo the screw cap completely and pull out the collet from the collet seat. Replace it with the new collet and screw the cap loosely back on.

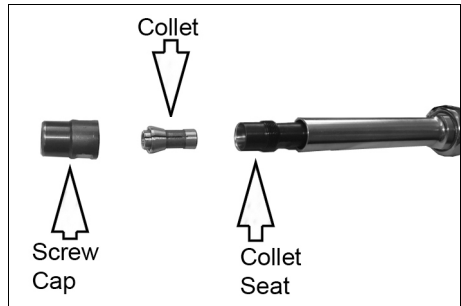

FITTING THE GRINDING STONE

IMPORTANT: Never use chipped or cracked grindstones. Never use grindstones not rated to operate at a speed equal to, or greater than, the full operating speed of the air tool.

1. Slip the shank of the chosen stone into the collet and tighten the screw cap finger tight.
2. Place the smaller of the two wrenches over the collet seat to stop the tool from rotating.
3. Use the larger wrench to fully tighten the collet and grip the stone in position as shown.

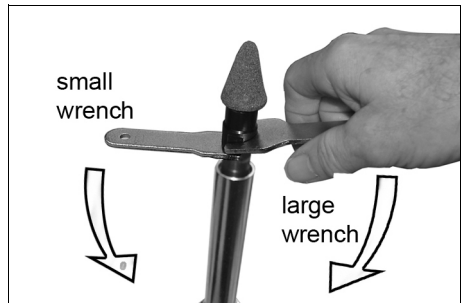

ADJUSTING THE SPEED

1. Set the tool speed by rotating the control to one of the four settings.
 - The graduations on the speed control indicate the speed setting when aligned with the reference mark on the air inlet.
 - Speeds available are: 12000, 17500, 22000 or 25000 rpm (+/- 10%).

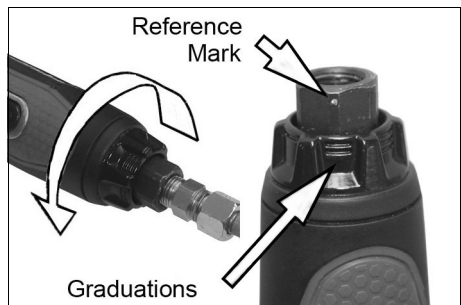

OPERATING THE DIE GRINDER

1. Use your thumb to slide the throttle locking lever forward while squeezing the trigger against the body of the tool.
2. Do not use excess pressure on the grinding stone as this will shorten its life.
3. Release the trigger to stop the grinder.
 - The tool will continue to rotate for a short time after the trigger has been released.
4. Always ensure the grinder has stopped before putting it down.



SETTING THE EXHAUST DEFLECTOR

The direction of the exhaust air leaving the tool can be adjusted by rotating the exhaust deflector.

Twist the exhaust deflector sleeve to direct the air as required to deflect air away from the workpiece or operator.

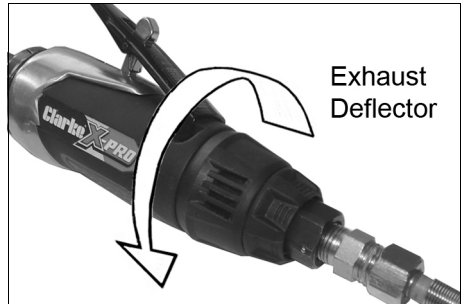

DISCONNECTING THE AIR SUPPLY

1. Do not disconnect the air supply hose until the compressor has been shut down and the compressed air released.
2. Refer to the compressor instruction manual for the procedure to shut down and release the compressed air.
3. Once the pressure has been released, disconnect the air supply hose from the tool.

STORAGE

If the tool is to be stored, or is idle for longer than 24 hours, run a few drops of Clarke air line oil into the air inlet, and run the tool for 5 seconds in order to lubricate the internal parts.

When not in use, disconnect from air supply, clean tool and store in a safe, dry place. When storing, ensure the blanking plug is replaced on the airline connector once the airline is disconnected.

TROUBLESHOOTING

SYMPTOM	PROBLEM	SOLUTION
Tool runs at normal speed but slows down under any load.	<ol style="list-style-type: none"> 1. Excessive pressure on tool. 2. Motor parts worn. 3. Worn or sticking mechanism due to lack of lubricant. 	<ol style="list-style-type: none"> 1. Reduce the force applied to the tool. 2. Return to Clarke dealer for repair. 3. Drip air tool lubricating oil into air inlet. Allow oil to soak moving parts before using.
Tool runs slowly. Air flows weakly from exhaust.	<ol style="list-style-type: none"> 1. Motor parts jammed with gum/dirt. 2. Regulator in closed position. 3. General airflow blocked by dirt. 	<ol style="list-style-type: none"> 1. Examine inlet air filter for cleanliness. 2. Adjust regulator to open position. 3. Operate tool in short bursts.
Tool will not run. Air flows freely from exhaust.	<ol style="list-style-type: none"> 1. Motor vanes stuck due to buildup of foreign material. 	<ol style="list-style-type: none"> 1. Disconnect air supply and rotate tool assembly manually. 2. Try operating tool in short bursts. 3. Drip a few drops of air tool lubricating oil into air inlet to soak moving parts.
Tool will not shut off.	<ol style="list-style-type: none"> 1. Throttle O-rings damaged or ill-fitting in seat. 	<ol style="list-style-type: none"> 1. Return to Clarke dealer for repair.

MAINTENANCE



WARNING: MAKE SURE THAT THE AIR TOOL IS DISCONNECTED FROM THE AIR SUPPLY BEFORE STARTING ANY CLEANING, OR MAINTENANCE PROCEDURES.

DAILY

1. Before use, drain water from the air tank, air line and compressor.
2. Pour a few drops of CLARKE airline oil, into the air inlet. This should be carried out regardless of whether or not an in-line mini oiler is used. If an in-line mini oiler is not used, this procedure should be repeated after every two to three hours of use.

WEEKLY

1. Check the air inlet screen filter for blockage and clean if necessary.

CLEANING

1. Keep the body of the tool clean and free from debris.
2. Grit or gum deposits inside the tool may also reduce its efficiency. This condition can be corrected by cleaning out the air strainer and flushing out the tool with gum solvent or oil, or failing this, the motor may require dismantling. This is better left to your Clarke dealer.

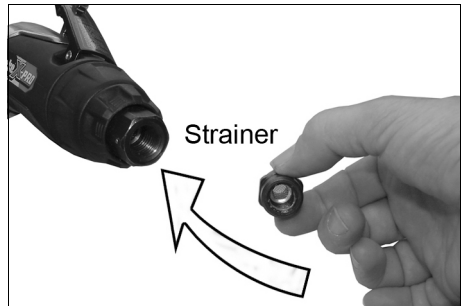

SERVICE AND REPAIR

If the tool runs erratically or becomes inefficient although the air supply is in good order, it may be necessary to dismantle the air motor and replace any worn or damaged parts. Such servicing and repair work should be carried out by a qualified service technician.

PERFORMANCE

Please note that factors other than the tool may effect its operation and efficiency such as reduced compressor output, excessive drain on the airline moisture or restrictions in the air-line, or the use of connectors of improper size or poor condition which will reduce air supply.

****Clarke Air Line Oil (part no. 3050825) is available from your CLARKE dealer.**

ACCESSORIES

A wide range of accessories is available including filter/regulators, lubricators, high-pressure hoses (5 to 50 metres) etc.

Contact your CLARKE dealer for further information or CLARKE International Service Department.

SPECIFICATIONS

Model Number	CAT130
Dimensions (L x W x H)	300 x 67 x 44 mm
Weight	0.7 kg
Air Inlet Size	1/4" BSP (female)
Operating Pressure	90 psi (6.2 bar)
Air Consumption	4 cfm average /15 cfm at max load
No Load Speed	25,000 rpm @ 90psi
Sound Pressure Level (LpA dB)	88 dB(A)
Sound Power Level (LwA dB)	99 dB(A)
Vibration Levels	2.9 m/s ²

Please note that the details and specifications contained herein are correct at the time of going to print. However CLARKE International reserve the right to change specifications at any time without prior notice. Always consult the machine's data plate.

PARTS LIST & DIAGRAM

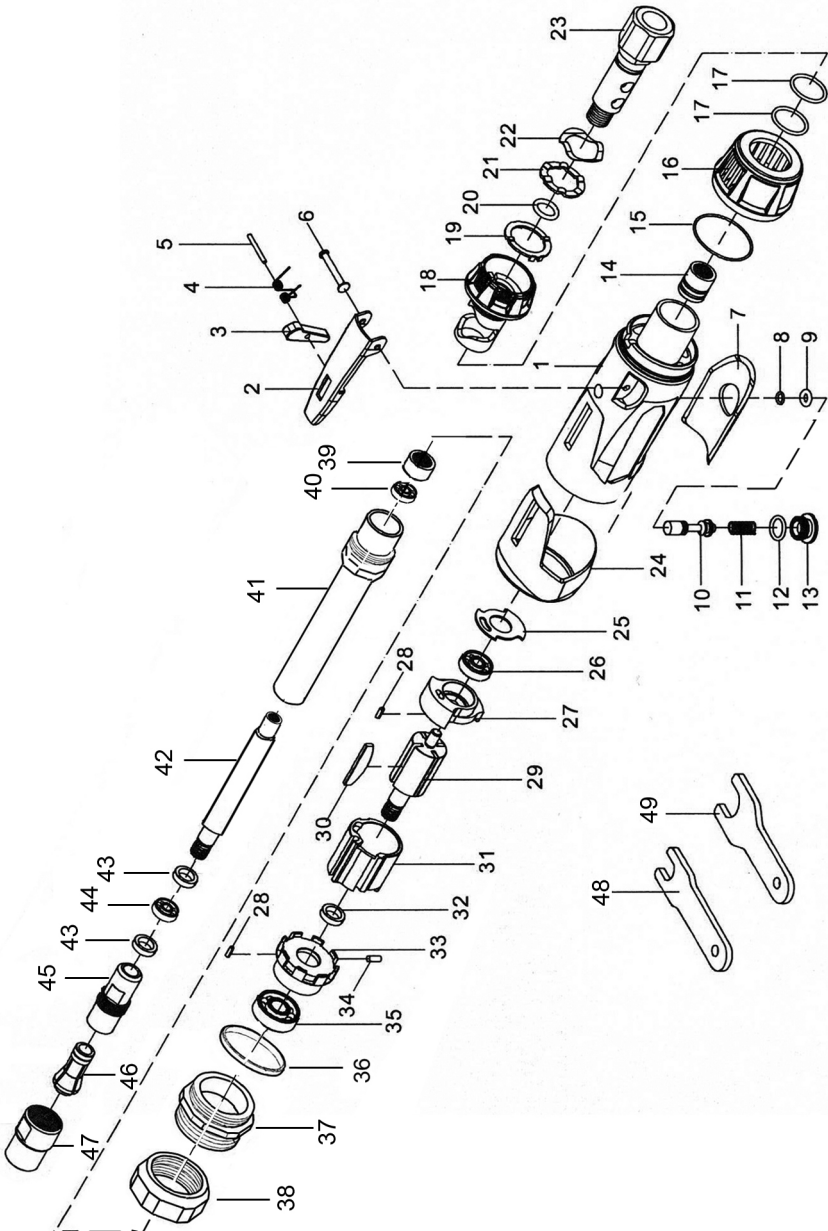

PARTS LIST & DIAGRAM

No	Description
1	Main Housing
2	Trigger
3	Throttle Locking Lever
4	Spring
5	Pin
6	Trigger Pin
7	Soft Grip
8	O-Ring
9	O-Ring
10	Valve Stem
11	Valve Spring
12	O-Ring
13	Valve Plug
14	Regulator Valve Bushing
15	O-Ring
16	Exhaust Deflector
17	O-Ring
18	Air Regulator
19	Set Plate
20	O-Ring
21	Set Plate
22	Gasket
23	Air Inlet
24	Housing Cover
25	Gasket

No	Description
26	Rear Rotor Bearing
27	Rear Motor Plate
28	Pin
29	Rotor
30	Rotor Blade
31	Cylinder
32	Rotor Collar
33	Front Plate
34	Pin
35	Front Rotor Bearing
36	Sealing Ring
37	Fixing Ring
38	Chrome Nut
39	Hex Spacer
40	Bearing
41	Drive Shaft Housing
42	Drive Shaft
43	Bearing
44	Bearing
45	Collet Holder
46	Collet
47	Screw Cap
48	Small Wrench
49	Large Wrench

DECLARATION OF CONFORMITY



Fitzwilliam Hall, Fitzwilliam Place, Dublin 2

DECLARATION OF CONFORMITY

This is an important document and should be retained.

We hereby declare that this product(s) complies with the following directive(s):
2006/42/EC Machinery Directive

The following standards have been applied to the product(s):

EN ISO 11148-9:2011

The technical documentation required to demonstrate that the product(s) meet(s) the requirement(s) of the aforementioned directive(s) has been compiled and is available for inspection by the relevant enforcement authorities.

The CE mark was first applied in: 2013

Product Description: 1/2 Air Die Grinder
Model number(s): CAT128, CAT129, CAT130, CAT143
Serial / batch Number: N/A
Date of Issue: 20/05/2022

Signed:

J.A. Clarke
Director

CAT130 CE Clarke.DOC 032022

Page 1 of 1



Hemmill Street, Epping, Essex CM16 4LG

DECLARATION OF CONFORMITY

This is an important document and should be retained.

We hereby declare that this product(s) complies with the following statutory requirement(s):
Supply of Machinery (Safety) Regulations 2008

The following standards have been applied to the product(s):

EN ISO 11148-9:2011

The technical documentation required to demonstrate that the product(s) meet(s) the requirement(s) of the aforementioned legislation has been compiled and is available for inspection by the relevant enforcement authorities.

The UKCA mark was first applied in: 2022

Product Description: 1/2 Air Die Grinder
Model number(s): CAT128, CAT129, CAT130, CAT143
Serial / batch Number: N/A
Date of Issue: 20/05/2022

Signed:

J.A. Clarke
Director

CAT130 UKCA Clarke.DOC 032022

Page 1 of 1

A SELECTION FROM THE VAST RANGE OF

Clarke®

QUALITY PRODUCTS



AIR COMPRESSORS

From DIY to industrial, Plus air tools, spray guns and accessories.

GENERATORS

Prime duty or emergency standby for business, home and leisure.

POWER WASHERS

Hot and cold, electric and engine driven - we have what you need

WELDERS

Mig, Arc, Tig and Spot. From DIY to auto/industrial.

METALWORKING

Drills, grinders and saws for DIY and professional use.

WOODWORKING

Saws, sanders, lathes, mortisers and dust extraction.

HYDRAULICS

Cranes, body repair kits, transmission jacks for all types of workshop use.

WATER PUMPS

Submersible, electric and engine driven for DIY, agriculture and industry.

POWER TOOLS

Angle grinders, cordless drill sets, saws and sanders.

STARTERS/CHARGERS

All sizes for car and commercial use.

PARTS & SERVICE:

0208 988 7400

Parts Enquiries

Parts@clarkeinternational.com

Servicing & Technical Enquiries

Service@clarkeinternational.com

SALES: UK 01992 565333 or Export 00 44 (0)1992 565335

Clarke INTERNATIONAL Hemnall Street, Epping, Essex CM16 4LG
www.clarkeinternational.com